

PARTS LIST				
ITEM	QTY	PART NUMBER	REV	CODE
1	2	RFM2-CASTERPAD-24	01	
2	2	2.5 TCH-Caster Wheel-F	00	TCH-218
3	2	2.5 TCH-Caster Wheel-S	00	TCH-217
4	16	5/16 FLAT WASHER BLK ZINC	00	AL4-080
5	16	1/4-20 Keps Nut	00	PAU-006
6	4	10-32 Acorn Nut	00	AL4-052
7	4	10-32 x.500 FLAT HEAD MS	00	AL4-099

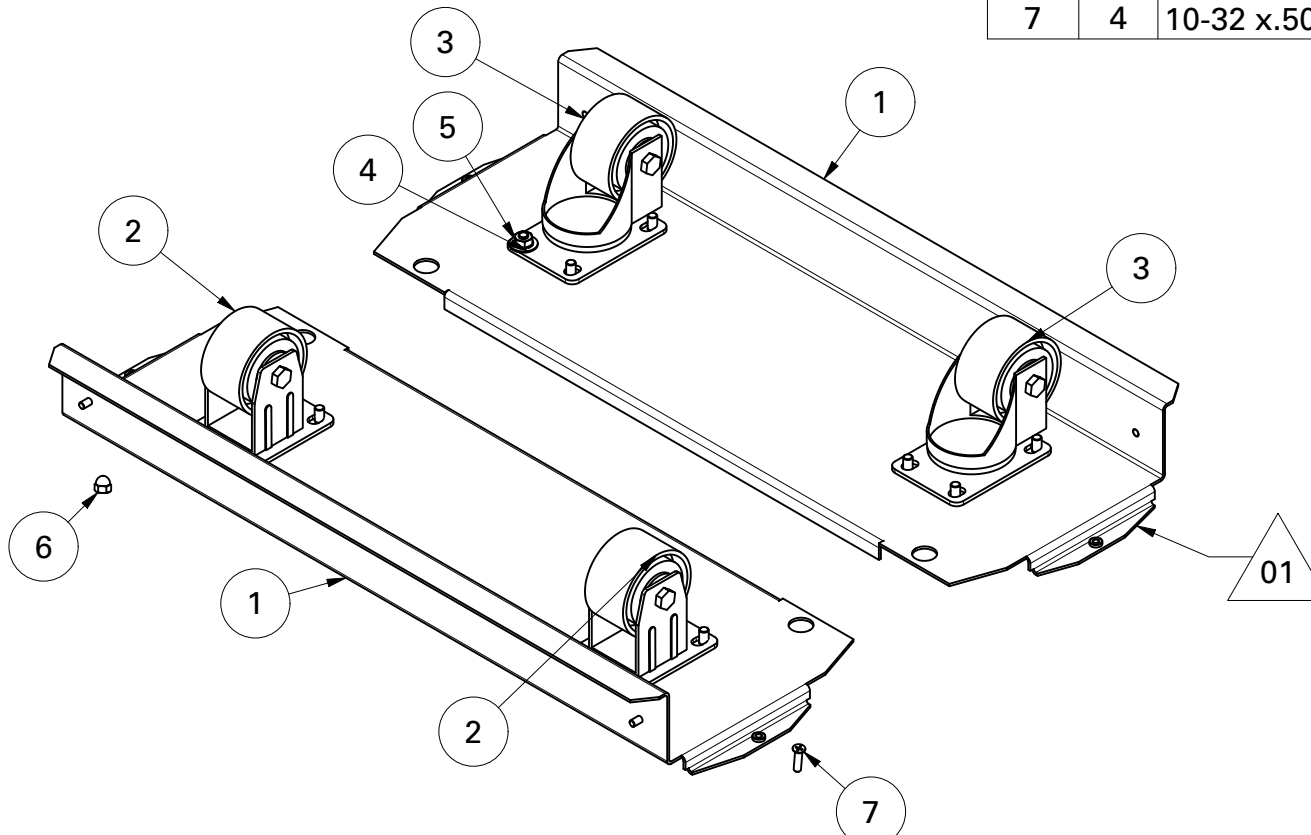

R.F. MOTE
A division of Chatsworth Products

214 NEWKIRK RD.
RICHMOND HILL, ONTARIO
L4C 3G7
PHONE (905) 884-5250
FAX (905) 737-5188

TOLERANCES	DESCRIPTION	DATE	MASS	REV
FRAC. ± 1/16"	2.5" CASTER PAD FOR 24"W RFM2 CABINET 2 SWIVEL AND 2 FIXED	17-Jan-24	13.1 lb	01
ANGLE ± 1.0°				
HOLES ± 0.003"	PART NUMBER			
0.000 ± 0.015"	RFM2-2C-B-24			
	AUTHOR			
	gillison j			

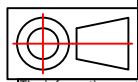

The information contained herewith is proprietary and confidential to R.F.MOTE LTD. It may not be reproduced or further disseminated, in whole or in part, without prior written consent from R.F.MOTE LTD.